

ORGANIC RANKINE CYCLE SYSTEMS FOR WASTE HEAT RECOVERY IN MARINE APPLICATIONS

S. Bellolio¹, V. Lemort¹, P. Rigo²

¹Thermodynamics Laboratory, University of Liège, Campus du Sart Tilman, Batiment B-49, Parking P33, 4000 Liège, Belgium, sabellolio@ulg.ac.be

²ANAST, University of Liège, Campus du Sart Tilman, Batiment B-52, Parking P52, 4000 Liège, Belgium

ABSTRACT

In marine applications powered by internal combustion engines, a considerable amount of the energy contained in fuel is wasted through thermal losses. Additionally, as the years go by, new and more severe standards and regulations are imposed to the maritime industry. Despite of the traditional use of the waste heat recovery systems in ships, in order to meet new emissions demands, the research towards less traditional ways to reduce vessels emissions has been pushed. Nowadays the use of Organic Rankine cycles (ORC) seems to be a very promising solution to increase the global efficiency in maritime applications by converting the vessel's thermal losses into useful work. Even if ORC's have been studied during the last decades, it is only in the recent years that the maritime industry has drawn its attention towards these systems. In the first part of this paper, a state of the art of ORC in marine applications is performed. Then, the use of an ORC over traditional waste heat recovery methods (steam Rankine cycles) used in ships is discussed. Finally, a thermodynamic steady-state model of an ORC is coupled to a vessel ICE to estimate the improvements in energy efficiency that could be achieved by implementing an ORC in a vessel.

Keywords: Waste heat recovery, Organic Rankine cycle, Internal combustion engine, Marine

1. INTRODUCTION

The new impositions and restrictions imposed to ships emissions and also the global tendency of developing greener ships has pushed and motivated the research towards the improvement of the efficiency of ships. An increase of a vessel's efficiency can be achieved following different energy efficiency approaches such as increasing the thrust efficiency, reducing the aero and hydrodynamic resistances of the ship and improving the auxiliary machinery and engine efficiencies (Wang and Lutsey, 2013). The efficiency of a ship will depend to a large extent on the adoption of the mentioned energy efficiency measures. The JOULES project is a project founded by the European Union and it is focused on the integration of energy saving technologies in order to find the optimum energy grid that will lead to significant improvements of the ship's efficiency (JOULES, 2013).

Within ships, the major source of energy losses is located in the engine (Suárez and Greig, 2013). For that reason, the improvement of the engine efficiency can lead to a significant reduction of the fuel consumption of a vessel. Besides of the high efficiencies (near 50%) that marine engines have achieved during the last decades, there is still a considerable amount of heat that is lost mainly through the engine's jacket cooling system (between 343 and 363 [K]), air charge cooler (between 363 and 473 [K]) and exhaust gases (between 523 and 625 [K]). About one half of the total waste heat is released through the exhaust gases (MAN, 2014). Additionally, among the different waste heat sources of the ship, the main engine exhaust gases are the most attractive due to their high exergetic content. Figure 1 shows the typical energetic and exergetic distribution of the waste heat from a modern marine diesel engine.

Energetic distribution of waste heat

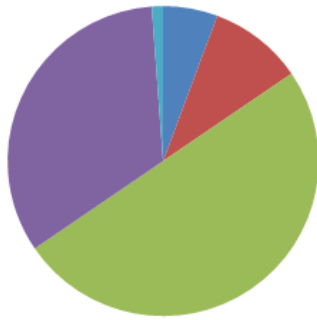

Exergetic distribution of waste heat

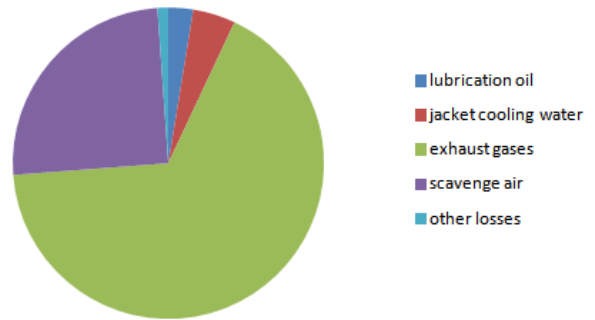

Figure 1. Typical energetic and exergetic distribution of waste heat from a modern marine Diesel engine.

Waste heat recovery in ships appeared in the 1970's in the United States and in Europe, mainly as a consequence of the first oil crisis (Song et al., 2015). During the last decades several techniques have been applied to valorize the energy that is rejected during the operation of the main propulsion systems.

Adamkiewicz and Wietrzyk (2009) analyzed the use of power turbines to utilize the energy contained in the exhaust gases of the main engine. A part of the exhaust gas stream is bypassed from the exhaust manifold of the engine and is used to run the power turbine. To ensure the correct operation of the turbine it should work at main engine loads above 50% of the engine rated power. It is estimated that the use of a power turbine could lead to fuel saving of 2000 [t] of fuel oil per year in big marine propulsion plants.

Ouadha and El Gotni (2013) investigated the integration of a water-ammonia absorption refrigeration system driven by the waste heat of a marine Diesel engine. A thermodynamic analysis of the cycle showed that a higher performance of the system is obtained with higher temperatures of the absorber and the evaporator. (Bouazzaoui et al., 2008) proposed the use of a two-stage absorption-desorption cycle to satisfy the cooling needs of a fishery trawler ship. The system runs by high and medium waste heat coming from the main engine of the vessel at two levels of temperature. After comparing with a single stage cycle, it was proven that the use of a two-stage cycle allows an increase of 25% in the cooling capacity

Waste heat coming from the engine can also be used for desalinization of the sea water and satisfy the fresh water demand of a vessel. For that purpose, the use of heat driven units such as multi stage flash and multiple effect distillation can be considered (Shu et al., 2013).

Hatchman (1991) studied the application of a single and a dual-pressure steam Rankine cycle to recover heat of the exhaust gases of a marine slow speed engine fueled by fuel oil with a maximum continuous rating (mcr) power output of 5850 [kW]. The study showed that the power output of the heat recovery system is proportional to the engine load and that at engine mcr output, an amount of 780 [kW] could be recovered. A dual-pressure system with external heating (the low pressure superheater is omitted) is the most efficient plant. Although water is still the main working fluid on Rankine cycles in ships, application of organic fluids shows a great potential for the future (Shu et al., 2013).

2. ORC TECHNOLOGY

An ORC applies the same principles than a steam Rankine cycle but uses organic working fluids with low boiling points to recover heat from lower temperature heat sources. The ORC is a closed thermodynamic cycle that is composed by the following processes: working fluid compression, heat admission (from a waste heat source in case of ships), working fluid expansion and heat rejection. Figure 2 depicts the T-s diagram of a typical ORC using R245fa as working fluid. The thermal energy recovered from the waste heat source is transformed via the ORC into mechanical power (eventually transformed into electrical power) that helps to cover the ship's energy demand. Since a part of the energetic demand of the ship is covered by the ORC, there is a reduction in the fuel consumption and therefore a reduction in the emissions of the vessel.

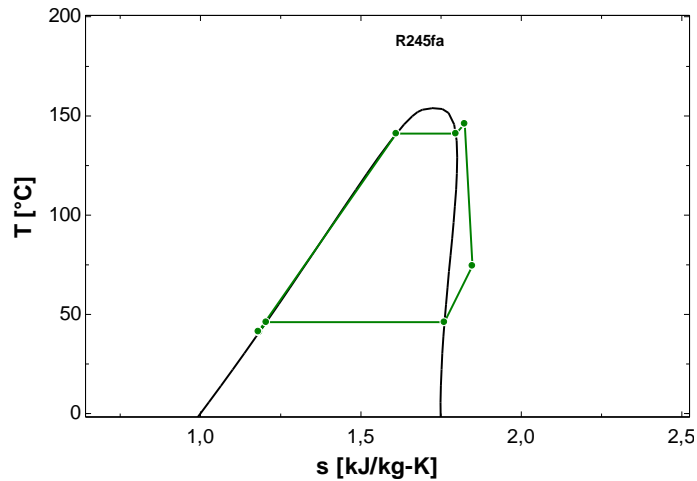

Figure 2. T-s diagram of a typical ORC using R245fa as working fluid.

The fluids used in ORC's are from different natures such as Hydrocarbons, Siloxanes, Alcohols, Ethers among others. Suitable working fluids have a lower latent heat than water and for that reason, less heat is needed to vaporize the working fluid. Additionally, organic fluids have a better match with the heat source, reducing the irreversibility associated with the heat transfer process in the heat admission phase of the cycle. The lower latent heat of organic fluids requires the use of larger mass flow rates in comparison to steam Rankine cycles. This translates in higher pumps consumptions compared to the power output of the cycle. Therefore the pump efficiency is a parameter of the ORC that plays an important role in the cycle performance.

The different working fluids can be classified in three groups according to the slope of the saturated vapor line in the T-s diagram (Chen et al., 2010). As it is shown in Figure 3, a dry fluid has a positive slope, wet fluids have a negative slope and isentropic fluids have an infinite slope. Dry fluids have the particularity to remain in a superheated state after an isentropic expansion from saturated vapor conditions. Nevertheless, since there is still a degree of superheating after the expansion an amount of heat needs to be rejected before starting the condensation process.

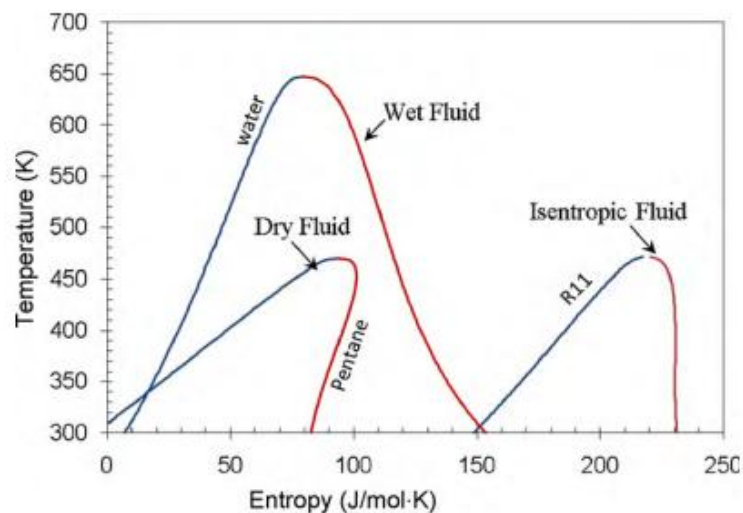

Figure 3. T-s diagram of the three main groups of working fluids (Chen et al., 2010).

It is desired for a working fluid to have a good thermodynamic performance in order to achieve high efficiencies and power outputs for an available heat source. Even though, there are also other desired characteristics that the working fluid should gather such as low viscosity, high thermal conductivity, high vapor density, thermal stability, low environmental impact (low ODP and GWP), high safety levels, condensation pressure higher than atmospheric pressure, non corrosivity, high availability and low cost. The type of fluid used in an ORC also

impacts the plant size, having an influence on the size of the required heat exchange surfaces, mass flow rates and expander size. Since space availability is one of the major constraints onboard, the size of the components associated to the different working fluids should also be taken into account. Unfortunately, some working fluids can be toxic or highly flammable making leakages very dangerous. This aspect has special significance in atmospheres where the ventilation and evacuation of dangerous gases is difficult such as inside the hull of a ship. To avoid unfortunate accidents it is mandatory to ensure the full tightness of the ORC. Unlike water, organic fluids usually suffer chemical deterioration and decomposition at high temperatures (Quoilin et al., 2013) making the thermal stability of the working fluid the main limitation of the application of ORC's with high temperature heat sources. Considering the above, in order to protect the working fluid from too high temperatures and to prevent situations where a leakage can get in contact with high temperature gases (causing a fire or an explosion), an intermediate loop of heat transfer fluid is used to transmit heat from the heat source to the boiler. This system also provides flexibility for the plant installation and reduces the piping length of the ORC, reducing also the cost associated to the working fluid and the risk of leakages. The intermediate loop also contributes to the controllability and stability of the ORC system by damping fast variations of the heat source, allowing a smoother operation (Quoilin et al., 2013).

The overall efficiency, safety, environmental impact and economic viability of the plant depend in a great extent on the selection of the working fluid. Nevertheless, no fluid has been identified as an optimum working fluid and therefore the selection of the working fluid is about finding the best compromise of properties. (Kölsch and Radulovic, 2015) investigated the potential of three different working fluids to be used in an ORC for waste heat recovery in a Diesel engine. In the study, thermodynamic and safety aspects were taken into account, as well as the size of the components of the cycle. Toluene had the highest net power output, nevertheless the best compromise between size of heat exchanger and thermodynamic performance was found for Methanol. However, toxicity and high flammability remain obstacles for their application in ORC systems. (Wang, 2010) studied the performance of different organic working fluids for waste heat recovery in automotive internal combustion engines. Simulation results presented the working fluids R11, R113, R141b and R123 as candidates to be used for waste heat recovery in internal combustion engines, mainly because of their high thermodynamic performance. Nevertheless, if safety levels and environmental impacts are considered, R245fa and R245ca are the most suitable working fluids for an engine waste heat recovery application. (Tian et al., 2012) studied the use of ORC as a bottoming cycle to recover waste heat from the exhaust of a commercial Diesel generator with a power output of 235.8 [kWe]. The unit is driven by an inline six cylinder four stroke supercharged Diesel-oil-fired engine. After performing a techno-economic analysis of the system operating with twenty different working fluids, it was concluded that the best performances are achieved with the fluids R141b, R245fa and R123. Nevertheless, R141b is the fluid that presented the lowest electricity production cost. Due to their suitability for heat recovery from low and medium temperature heat sources, the use of ORC has been proposed for different applications. The most common applications are: geothermal power plants, decentralized biomass cogeneration plants, solar power plants and waste heat recovery from industrial processes and internal combustion engines. ORC's in automotive applications powered by internal combustion engines has been concentrated on land based systems, mainly in waste heat recovery in passenger vehicles and long haul trucks. (Katsanos et al., 2010) studied the use of an ORC to recover waste heat from the exhaust gases and exhaust gas recirculation system of a heavy duty truck powered by a Diesel engine. Simulations results showed that an ORC using R245ca as working fluid could reduce the bsfc by 10.7% at 100% of the engine load. This improvement is considerably higher than the one obtained using steam as working fluid. Although even if the ORC is a well established and increasing form of energy production, it is a rather new technology in the marine market.

3. ORGANIC RANKINE CYCLES IN MARINE APPLICATIONS

In comparison with other mobile applications, the knowledge that has been produced about the performance of ORC's in marine applications is limited. (Song et al. 2015) examined the waste heat recovery of a 996 [kW] marine Diesel engine using ORC's. In the study, a stream of 7139 [kg/h] of exhaust gases coming from the engine at 573.15 [K] and a stream of 6876 [kg/h] of water coming the jacket cooling system at 363.15 [K] were considered as waste heat sources. Two different configurations for the waste heat recovery system were proposed. The first configuration considered two independent ORC systems, one using R245fa as working fluid

(to recover heat of the exhaust gases) and a second one using benzene as working fluid (to recover waste heat from the jacket cooling water). The second configuration consisted in a single ORC using the jacket cooling water as a preheated medium. A thermodynamic analysis showed that the first configuration is able to reach a maximum net power output of 101 [kW], increasing the engines power by 10.2%. Simulation results of the second configuration showed that the heat recovery system using cyclohexane as working fluid is capable to produce a net power output of 99,7 [kW]. Since the two systems presented a difference of only 1.4% in the net power output, the use of the jacket cooling water as a preheating media for the cycle is preferred over the configuration consisting in two independent ORC's. Additionally it is evident that the system containing two separated ORC's is more complex and requires a large amount of space, which might limit its application in ships.

Reini and Pinamonti (2015) examined the option of recovering energy from an internal combustion engine for ship propulsion using a bottom ORC. In the study a dual fuel engine (six cylinder in line) with a power output of 5.7 [MW] and an efficiency of about 49% is considered for the ship propulsion. After performing a non exhaustive fluid selection it was found that toluene was the best candidate to recover waste heat from a stream of hot gases at 623 [K]. Once the working fluid was selected, different bottoming cycle configurations were compared: simple ORC, regenerative ORC, preheated ORC and ORC with two different thermal levels. The regenerative cycle system is obtained by adding an internal heat exchanger to the simple cycle system, the preheated cycle system is obtained by adding a heat exchanger before the evaporator which preheats the working fluid with water from the HT cooling circuit. The last configuration is obtained by combining one cycle at high temperature, using toluene as working fluid with a cycle at lower temperature using isobutane as working fluid. Simulations revealed that a significant power gain (about a 10%) can be achieved with the simple cycle. The use of the cooling water as heat source might involve the use of an additional heat exchanger in order to avoid having too low return temperatures of the HT cooling water. According to the study, the regenerated ORC has the best compromise between performance and plant complexity. After performing a thermo economic analysis, it was estimated that the addition of a bottom ORC to the propulsion system has a payback time equal to about 6 years.

Yun et al. (2015) presented a system with dual ORC loops in parallel to recover waste heat from marine applications. The goal of the system is to improve the waste heat recovery when the waste heat presents large variations and the ORC works under off design conditions. The proposed system recovers heat from the exhaust gas stream and consists of two ORC's of different sizes (140 and 60 [kW]) using R245fa as working fluid. The exhaust gas, after passing through an economizer, is introduced into the ORC loops. The system can be selectively operated to work in single or dual mode. The power output of the dual ORC system was compared to the power output of a single ORC unit of 200 [kW]. Numerical simulations were performed considering different amounts of available waste heat. The results showed that the dual ORC system is able to achieve a power outputs from 3 to 15% higher than a single ORC unit. Nevertheless, the study does not compare the solutions from a thermo economical point of view.

Besides of the theoretical research studies that are being performed in the field of marine ORC's, some marine equipment manufacturers and shipyards have involved themselves with the concept of ORC systems for waste heat recovery in marine applications. In 2010, after the positives results that Turboden has achieved in the field of waste heat recovery in stationary internal combustion engines, Turboden and Wärtsilä have signed an agreement to develop, market and distribute an ORC solution specifically applicable to the marine market. The solution consists in the Wärtsilä Marine Engine Combined Cycle (ECC) and it is based on an ORC to recover waste heat from the exhaust gases and the jacket cooling water circuit. It is claimed that the system could increase the engine power in a range from 8 to 12% (Turboden, 2010). In 2015 the ORC manufacturer Enertime has received a funding from the European Union to implement its ORC technology in large ships by working in partnership with the shipyard STX France (Enertime, 2015). During the last years Enertime has been developing ORC modules designed to recover heat from marine vessels and cargo ships. The modules have been downsized as much as possible to fit in the limited space onboard. In 2011 the Opcon group has signed a cooperation agreement with MAN Diesel & Turbo to combine Opcon technology for energy efficiency with MAN Diesel & Turbo diesel engines for reduced fuel consumption and emissions (Opcon, 2011).

Regarding to existing marine ORC applications, the literature is very scarce and only few examples can be found. The Group Opcon has mounted two of their ORC module for marine applications onboard of a Wallenius marine vessel (*MV Figaro*). The heat recovery units, designed to recover heat from a low grade heat sources, is powered by the hot water of the vessel's cooling system. The higher ORC unit is able to generate up to 500 [kW] and the fuel savings are expected to be around 4-6%. The ORC system is coupled to an Opcon Powerbox WST system that is powered by the surplus steam available in the vessel. This system consists in a special steam turbine that generates electricity from wet or saturated steam (Opcon, 2012).

4. ADVANTAGES OF ORC SYSTEMS OVER TRADITIONAL HEAT RECOVERY CYCLES

Steam-based waste heat recovery systems for both four- and two-stroke engines are available commercially, among others by MAN, Wärtsillä, Alfa Laval (Baldi and Gabrielli, 2015). Some of these solutions combine the use of a steam cycle with the use of a turbocharger bypass in connection with a power turbine (MAN, 2014). Although waste heat recovery systems based on Steam Rankine cycle deliver good results, it is possible to increase thermal efficiency and power output from a low/ medium quality heat source using organic fluids instead of water. In a study performed by (Grljusic et al., 2014), a cogeneration plant for combined heat and power (CHP) is studied using low temperature waste energy as heat source. The plant is meant to cover the heating and electricity demands of a Suezmax size oil tanker during navigation. In the study, a supercritical ORC CHP plant using R245fa as working fluid is compared with a CHP plant based on a Steam Rankine cycle. Both plants are provided with a fuel-fired boiler to provide a supplementary amount of thermal energy when the waste heat is not enough to cover the ship demand or when the ship is at port and the main engine is shut down. Simulation results showed that in terms of fuel savings, the ORC plant presents a significant advantage over a traditional steam cycle over the entire operational range of the main engine. The fuel savings in the ORC compared to the steam cycle range from 400 and 927 [t] of fuel per year. Additionally, the study proved that an ORC plant is able to meet all the demands for electrical and thermal energy while burning only a small amount of fuel in the auxiliary boiler. (Suárez and Greig, 2013) simulated a plant based on a Rankine cycle for waste heat recovery from the exhaust gases of a 14-cylinder slow speed MAN Diesel & Turbo engine fueled by marine Diesel oil with a power output of 87.2 [MW] at full load. The objective of the study was to compare the waste heat recovery performance of different working fluids under different loads conditions of the ships main engine. The results of the study showed that among the five studied working fluids, Benzene is the working fluid that is able to deliver the maximum net power output 2,233 [kW]. It was also seen that the best performance of the ship waste heat recovery system was located in the higher engine loading region because of the higher amount and quality of the exhaust gases. Under all the scenarios considered in the study, the use of water as working fluid presented the worst performance in terms of efficiency and power output. (Larsen et al.2014) performed a study to compare the waste heat recovery performance of a steam cycle, a Kalina cycle and an ORC using R254ca as working fluid. The systems were applied to a feeder class container ship powered by a MAN Diesel & Turbo 7L70MC two-stroke slow speed engine with 7 cylinders each with a bore of 70 [cm] and a continuous power rating of 20 [MW]. The exhaust gases, charge air and jacket cooling water were used as waste heat sources. The three systems were simulated and optimized using a genetic algorithm. Results showed that an ORC can contribute with a 7% additional power while the steam and Kalina cycles contribute only with a 5% of additional power. Additionally, it was stated that a Kalina cycle does not offer any significant advantage in comparison with a steam cycle or ORC. It was concluded, that the ORC plant offers the simplest plant layout with the highest efficiency.

Besides of the superior performance using low grade heat sources, the use of waste heat recovery systems based on an ORC possess several technical advantages over traditional steam cycles. Dry fluids remain superheated after being expanded. For that reason, contrary to steam cycles, there is no need for superheating in the ORC to protect the turbine blades from entrained droplets that could impinge on the rotor blades causing erosion. This characteristic of the ORC makes the use of a superheater unnecessary and enables the use of lower temperatures at the turbine inlet, reducing the thermal stresses in the boiler. Some organic fluids have condensation pressures higher than the atmospheric pressure. This feature avoids the infiltration of non condensable gases in the condenser. Regularly steam plants have sub atmospheric condensing pressures and therefore the risk to have gaseous infiltrations that can damage the performance of the cycle. The high density difference existing between liquid and vapor phases in steam based cycles generates very different heat

transfer characteristics and for that reason complete evaporation in a single tube must be avoided. The density difference between vapor and liquid phases of organic fluids is relatively small allowing the use of once-through boilers. Due to this characteristic, the use of steam drums can be avoided simplifying in that way the layout and operation of the whole plant. Steam cycles must include a water deareator to avoid corrosion due to the presence of oxygen in the cycle. In ORC's the use of deareators or water treatment systems is not needed. In a steam cycle, the fluid density is extremely low in the low-pressure part of the cycle making necessary the use of large turbines, heat exchangers and hydraulic diameters for the pipes. The higher fluid density of organic fluids enables the use of compact equipment which is crucial in a marine application where the available space for the waste heat recovery plant is limited. The high enthalpy drops of steam cycles require the use of turbines with several expansion stages. Since the enthalpy drops in ORC is much lower, single stage and much simpler turbines are used. Normally, ORC's work at much lower pressure levels than steam cycles (rarely exceeding 30 [bar]). This feature reduces the complexity, cost and stress levels at the boiler. Considering the above, ORC is more interesting in the low to medium power range (KWe to a few MWe) mainly because of the simplicity of the cycle and its control and also for the use of simple and easy to manufacture components. Additionally, waste heat driven steam power plants are often not economical for power outputs below 5 [MW] and for low temperature waste heat streams (Shu et al., 2013). For higher power ranges, the steam cycle is generally preferred, except for low temperature heat sources (Quoilin et al., 2013).

5. CASE STUDY

As a case study, the use of an ORC plant for waste heat recovery from the exhaust gases of a vessel will be investigated. The vessel counts with two four-stroke engines used for ship propulsion and two four-stroke diesel engines used to power two gensets used for electricity generation. The engine loading conditions considered in this study will go from 50% to 100% of the engine mcr. The engines performance and the exhaust characteristics are displayed in Table 1.

Table 1. Engines performance and exhaust gas characteristics at different loads.

Engine type	Load [% mcr]	Power [kW]	Exhaust mass flow rate [kg/s]	Temperature [K]
Main engine	100	4500	8.10	653
	95	4275	7.54	639
	85	3825	7.44	609
	75	3375	6.64	618
	50	2250	5.57	588
Genset engine	100	3300	5.99	653
	95	3135	5.84	627
	85	2805	5.69	608
	75	2475	5.13	601
	50	1650	3.63	625

Unlike common automotive applications, where power is supplied by a single internal combustion engine, ships count very often with multiple engines. In this case of study the recovery of waste heat from multiple waste heat sources will be studied. An intermediate thermal oil loop and one recovery heat exchanger per engine will be used to recover waste heat from the exhaust gases. The use of one independent ORC unit per heat source might be impractical and would require sufficient available space. Additionally, the likelihood of a leakage and the investment and maintenance cost would increase. For that reason, a single ORC unit will be considered for the case of study. The intermediate oil loop will have a parallel configuration and it will be used to transmit heat from the heat sources to the ORC. The mass flow of oil flowing through each branch of the intermediate loop is regulated by means of valves and a variable speed pump. The mechanical power produced by the ORC will be used to run an electric generator which will help to cover the ship electrical demand. Figure 4 shows a scheme of the layout of the ship energy grid including the waste heat recovery system.

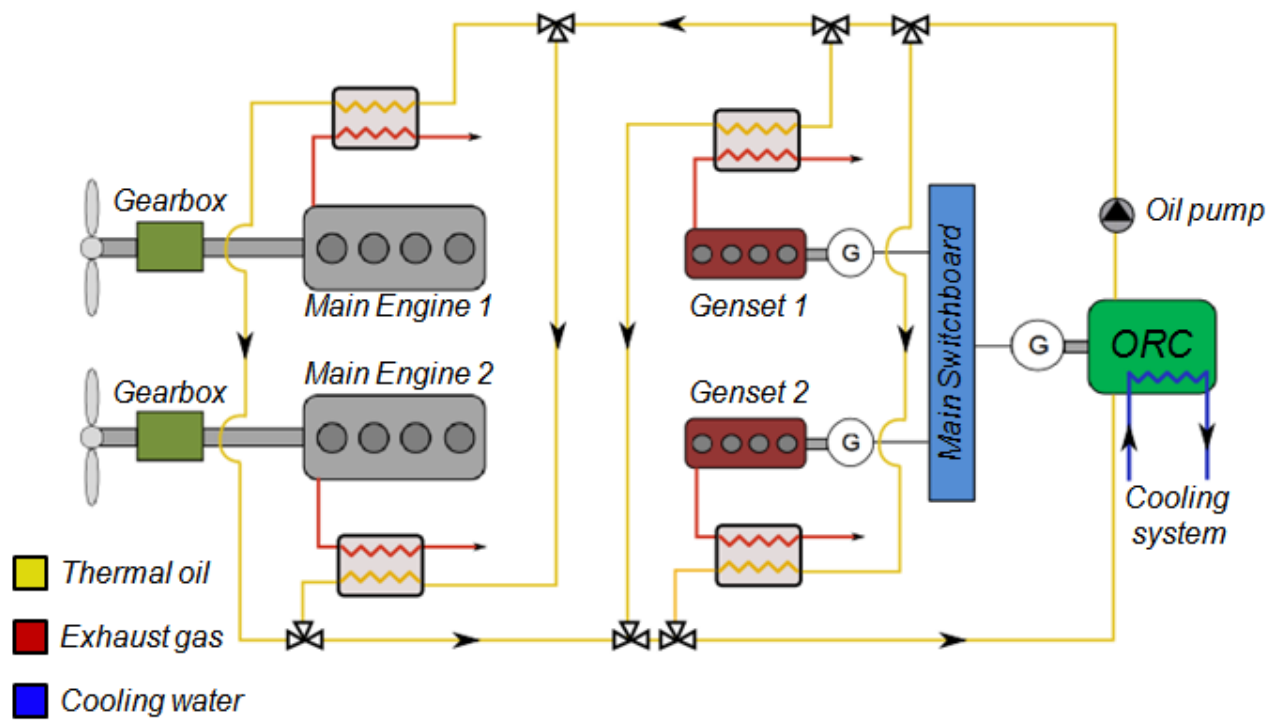

Figure 4. Layout of the vessel's energy grid including the waste heat recovery system.

Table 2. Details from the different operation modes.

Engine	Operation mode 1 [% mcr]	Operation mode 2 [% mcr]	Operation mode 3 [% mcr]	Operation mode 4 [% mcr]
Main engine 1	0.85	0	0.95	0.5
Main engine 2	0.85	0	0.95	0.5
Genset 1	0.95	0.75	0.5	0.5
Genset 2	0.95	0.75	0	0.5

Four different operation modes will be considered for the ship operation. The amount and quality of the waste heat coming from each source depends on the ship operation mode. The details of the prime movers operation in the different operation modes is displayed in Table 3. To estimate the potential of a waste heat recovery system based on an ORC plant, a thermodynamic model of the ORC will be used. The layout of the ORC used to convert the thermal energy of the exhaust gases into electric energy is displayed in Figure 5. The condenser and the evaporator were modeled following a three zone approach considering a constant pinch point. The pinch point of both heat exchangers is defined as the minimum temperature existing between the streams that exchange heat. The pump and the expander models are based in constant isentropic efficiencies. Is it assumed that the pumps of the waste heat recovery system are powered by electrical motors with constant efficiencies? The fluid R245fa will be considered as working fluid for the ORC. An internal recuperator has been included in the cycle. The recuperator is used to preheat the working fluid before entering the evaporator using the heat that is remaining after the expansion. The recuperator and the recovery heat exchangers are modeled using the effectiveness-NTU method and are considered as a perfect counter flow heat exchangers. In order to prevent the condensation of acids, a temperature of 433 [K] is established as the minimum temperature that the exhaust gases are allowed to achieve. The temperature and mass flow rate of thermal oil entering into the evaporator of the ORC is calculated by means of a thermal and a mass balance of the thermal oil stream. For the cooling system, it is assumed that an unrestrained mass flow of water at 308 [K] is available for heat rejection at the condenser.

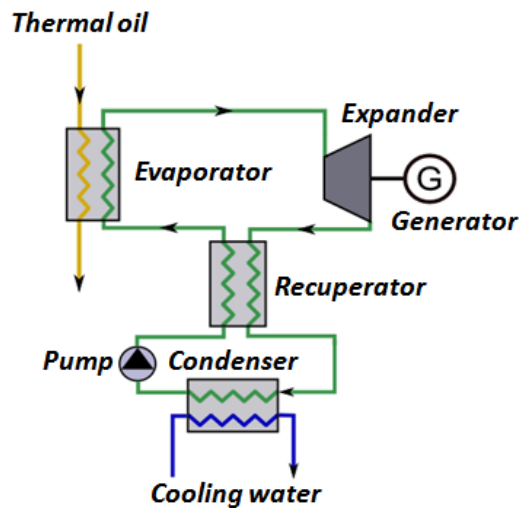

Figure 5. Layout of the ORC.

Part of the electrical power produced by the ORC is used to power the electric motors that run the oil and working fluid pumps. The model is a steady state model that has been programmed in Matlab. The properties of the working fluid were obtained from the working fluid database Coolprop. Table 3 displays the main parameters used in the model of the waste heat recovery system.

Table 3. Main parameters used in the model of the waste heat recovery system.

Parameter	Value
Superheating at evaporator outlet	5 [K]
Pinch point evaporator	10 [K]
Subcooling at condenser outlet	5 [K]
Pinch point condenser	10 [K]
Recuperator effectiveness	80 [%]
Pump isentropic efficiency	60 [%]
Expander isentropic efficiency	80 [%]
Recovery heat exchangers effectiveness	80 [%]
Electric motor efficiency (Pumps)	90 [%]
Generator efficiency	90 [%]
Recovery heat exchanger pressure drop (oil side)	0.1 [bar]

The model is used to estimate the energy efficiency improvements that could be expected by implementing an ORC in a vessel.

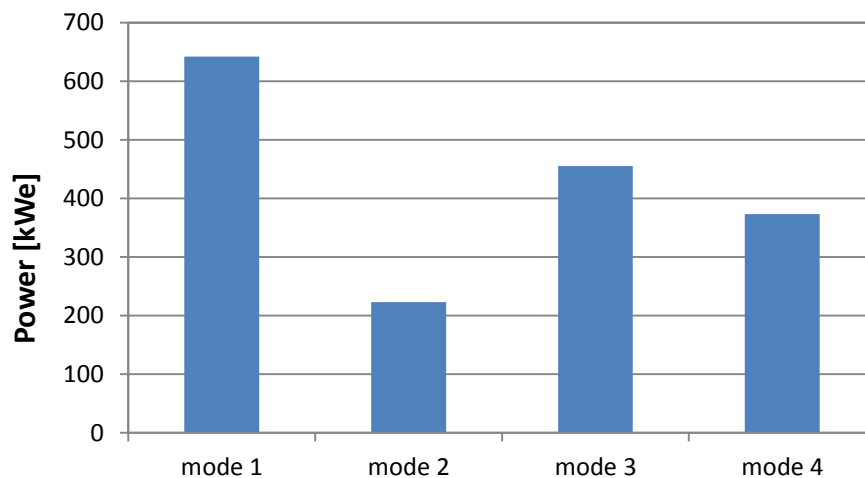

Figure 6. Power output of the waste heat recovery system at different operation modes.

The performance of the system has been calculated by performing simulations of the waste heat recovery system applied on the different operation modes of the ship. The mass flow rate of thermal oil and the oil mass flow rate distribution through the different branches of the intermediate loop have been calculated in order to maximize the exergy variation of the thermal oil. Additionally, the evaporation pressure of the working fluid has been optimized in order to maximize the power output of the cycle. Figure 6 shows the power output of the ORC under different operation modes. It can be appreciated that the highest power outputs can be found in the operation modes where the main engines operate at high loads. This is mainly due to the highest gas mass flow rates and exhaust temperatures of the main engines. The power output of the ORC ranges between 223 [kW] and 642 [kW], representing an increase in the vessel's power output ranging between 4 and 5%.

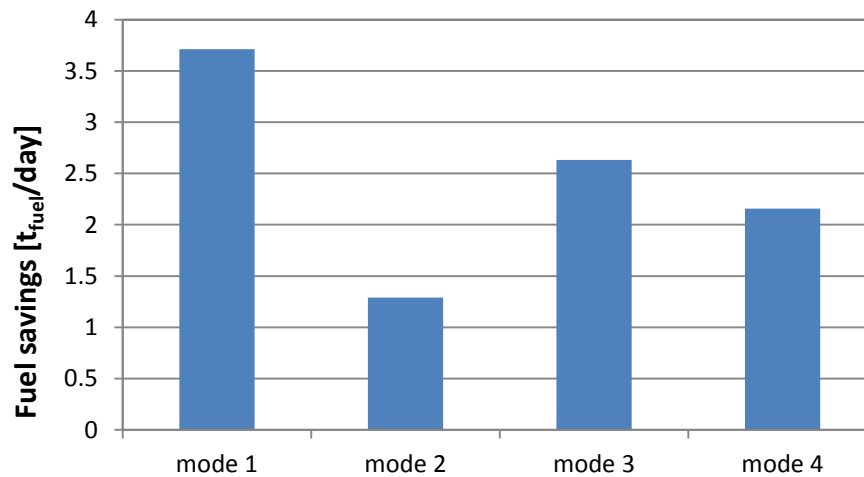

Figure 7. Daily fuel savings at different operation modes.

The fuel savings that are achieved by the implementation of an ORC in the ship are calculated as the amount of fuel that would be required to produce the same amount of electricity that is produced by the ORC using a genset. The vessel engines run using marine gas oil (MGO) with a lower heating value of 42700 [kJ/kg]. Figure 7 shows the daily amount of fuel that can be saved using the heat recovery system at the different operation modes. Considering that the vessel has a daily fuel consumption ranging between 20 and 61 [t_{fuel}/day], the implementation of the waste heat recovery system can lead to a 6% of reduction of the vessels fuel consumption.

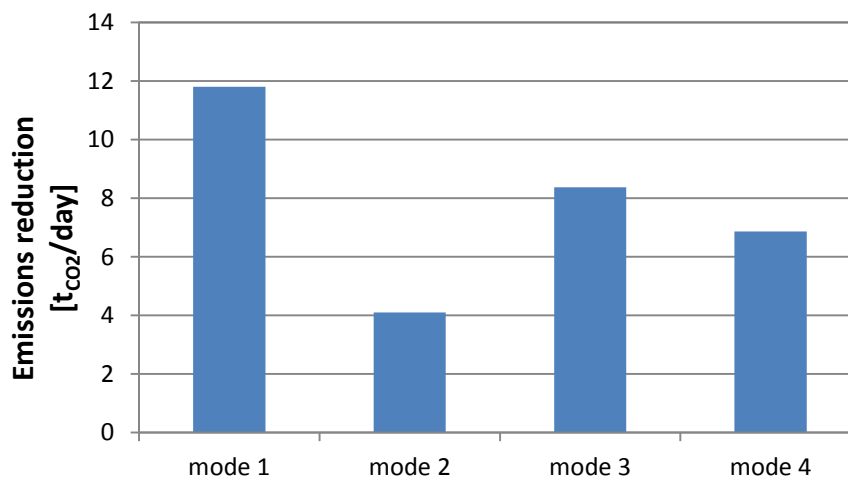

Figure 8. Daily reduction of CO₂ emissions at different operation modes.

The results of the fuel savings are used to estimate the daily reduction in the vessels emissions. To calculate the reduction of the emissions, 3.18 [t_{CO2}/t_{fuel}], 52 [kg_{NOx}/t_{fuel}], 19 [kg_{SO2}/t_{fuel}] and 4.5 [kg_{PM}/t_{fuel}] have been

considered as emission factors. Figure 8 and Figure 9 show, respectively, the daily amount of reduction in the CO₂ and harmful emissions that can be achieved at the different operation modes.

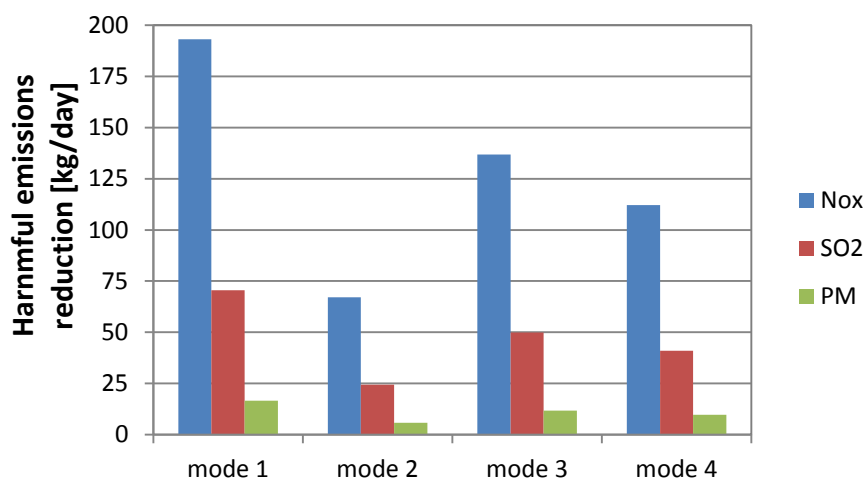

Figure 8. Daily reduction of harmful emissions at different operation modes.

By considering that the ship under study has an average operation of 315 [days/year], the annual fuel and CO₂ emissions savings can be estimated. The following operation profile will be taken into account: operation mode one is used during 65% of the vessels operational time while operation modes two, three and four are used during 5%, 20% and 10% of the operational time, respectively. If the performance decrease of waste heat recovery system due to the operation in off design is not considered, yearly fuel savings of 1014 [t] of MGO and yearly savings of 3224 [t] CO₂ in the vessels emissions can be expected.

6. CONCLUSIONS

In marine engines, a great extent of the energy contained in the fuel is lost in the way of thermal losses. Thermal losses have different origins being the exhaust gases the highest loss of the engine. Even if Organic Rankine Cycles are relatively new in the marine industry, they represent a very promising technology to recover waste heat in marine applications. These systems are a good alternative to traditional waste heat recovery technologies, mainly due to their simplicity and their good performance to recover heat from low and medium temperature sources. As a case of study the implementation of a waste heat recovery system based in an organic Rankine cycle has been studied. The study proposed the recovery of waste heat from multiple heat sources. Results based in simulations have shown that the use of an ORC can lead to an increase of the ship efficiency and a reduction of the emission. The results of this study could be improved by developing a model that can predict the performance of the waste heat recovery system working in off design conditions.

REFERENCES

- Adamkiewicz A., Wietrzyk B. (2009) 'Marine turbine application in waste heat recovery systems', Journal of Polish CIMAC, Vol. 4, No. 1, Gdansk University of Technology.
- Baldi F., Gabrielli C. (2015) 'A feasibility analysis of waste heat recovery systems for marine applications', Energy, 80, pp. 654-665.
- Bouazzaoui S., Infante C., Langreck J., Gerritsen J. (2008) 'Absorption resorption cycle for heat recovery of diesel engines exhaust and jacket heat', International refrigeration and air conditioning conference, paper 911.
- Chen H., Goswami Y., Stefanakos E. (2010) "A review of thermodynamic cycles and working fluids for the conversion of low-grade heat", Renewable and Sustainable Energy Reviews, 14, pp. 3059-3067.
- Enertime (2015), 'Enertime has received a finding from the European H2020 program to implement its ORC technology in large ships', Press release.

- Grljusic M., Medica V., Racic N. (2014) 'Thermodynamic Analysis of a Ship Power Plant Operating with Waste Heat Recovery through Combined Heat and Power production', *Energies*, 7, pp. 7368-7394.
- Hatchman J.C. (1991) 'Steam cycles for waste heat recovery: a case study', *N&O JOERNAAL*, September 1991, pp. 32-38.
- JOULES (Joint Operation for Ultra Low Emission Shipping) (2013), Project press release, www.joules-project.eu.
- Katsanos C., Hountalas D., Zannin T., Yfantis E. (2010) 'Thermodynamic analysis of a Diesel truck engine organic Rankine cycle', 7th International Conference on Heat Transfer, Fluid Mechanics, and Thermodynamics, 19-21 July 2010, Antalya, Turkey.
- Kölsch B., Radulovic J. (2015) 'Utilization of diesel engine waste heat by Organic Rankine Cycle', *Applied Thermal Engineering*, 78, 437-448.
- Larsen U., Sigthorsson O., Hanglind F. (2014) 'A comparison of advanced heat recovery power cycles in a combined cycle for large ships', *Energy*, 74, pp 260-268.
- MAN Diesel & Turbo (2014) Waste heat recovery system (WHR) for the reduction of fuel consumption, emissions and EEDI, Technical paper.
- Opcon (2011), 'Opcon signs co-operation agreement with MAN Diesel & Turbo', Press release.
- Opcon (2012), 'Commissioning and testing of first reference installation of Opcon technology for ships'.
- Ouahda A., El-Gotni J. (2008), 'Integration of a water-ammonia absorption refrigeration system with a marine Diesel engine: a thermodynamic study', *Procedia Computer Science*, 19, pp 754-761.
- Quoilin S., Van Den Broek M., Declaye S., Dewallef P., Lemort V. (2013) "Techno-economic survey of Organic Rankine Cycle (ORC) systems", *Renewable and Sustainable Energy Reviews*, 22, pp. 168-186.
- Reini M., Pinamonti P. (2015) 'Different Options for ORC's as Bottom for an Internal Combustion Engine for Ship propulsion', *Energies*, 2015, 8.
- Shu G., Liang Y., Wei H., Tian H., Zhao., Liu L. (2013), "A review of waste heat recovery on two-stroke IC engine aboard ships", *Renewable and Sustainable Energy Reviews*, 19, pp. 385-401.
- Song, J., Song, Y., Gu, C. (2015) 'Thermodynamic analysis and performance optimization of an Organic Rankine Cycle (ORC) waste heat recovery system for marine diesel engines', *Energy*, 82, pp 976-985.
- Suárez, S., Greig, A. (2013) 'Making shipping greener: ORC modeling under realistic operative conditions', *Low Carbon Shipping Conference*, London 2013.
- Tian H., Shu G., Wei H., Liang X., Liu L. (2012) "Fluids and parameters optimization for the organic Rankine cycles (ORCs) used in exhaust heat recovery or Internal Combustion Engine (ICE)", *Energy*, 47, pp. 125-136.
- Turboden (2010), 'Turboden and Wärtsilä sign agreement to launch Wärtsilä ECC', Press release.
- Wang E., Zhang H., Fan B., Ouyang M., Zhao Y., Mu Q. (2010), "Study of working fluid selection of organic Rankine cycle (ORC) for engine waste heat recovery", *Energy*, 36, 3406-3418.
- Wang H., Lutsey, N. (2013) 'Long term potential for increased shipping efficiency through the adoption of industry-leading practices', *The International Council on Clean Transportation*.
- Yun E., Park H., Youl S., Chun K. (2015) 'Dual parallel organic Rankine cycle (ORC) system for high efficiency waste heat recovery in marine application', *Journal of Mechanical Science and Technology*, 29, pp. 2509-2515.